

ZANUSSI

**BUILT-IN
DOUBLE OVEN
MODEL ZDM 891**

INSTRUCTION BOOKLET

Please read this instruction booklet before using the oven

Important Safety Information



You MUST read these warnings carefully before installing or using the oven. If you need assistance, contact our Customer Care Department on 08705 727727

Installation

- This oven must be installed by qualified personnel to the relevant British Standards.
- This oven is heavy. Take care when moving it.
- Remove all packaging, both inside and outside the oven, before using the oven.
- Do not attempt to modify the oven in any way.

Child Safety

- This oven is designed to be operated by adults. Do not allow children to play near or with the oven.
- The oven gets hot when it is in use. Children should be kept away until it has cooled.

During Use

- This oven is intended for domestic cooking only. It is not designed for commercial or industrial purposes.
- Never line any part of the oven with aluminium foil.
- Do not allow heatproof cooking material, e.g. roasting bags, to come into contact with oven elements.
- Never place plastic or any other material which may melt in or on the oven.
- Do not place sealed cans or aerosols inside the oven. They may explode if they are heated.
- Do not hang towels, dishcloths or clothes from the oven or its handle.
- Do not use this oven if it is in contact with water and never operate it with wet hands.
- Take great care when heating fats and oils as they will ignite if they become too hot.
- Always use oven gloves to remove and replace food in the oven.

- Ensure that all control knobs are in the OFF position when not in use.
- Do not leave cookware containing foodstuffs, e.g. fat or oil in or on the oven in case it is inadvertently switched ON.
- When using other electrical appliances, ensure the cable does not come into contact with the hot surfaces of the oven.

Maintenance and Cleaning

- Only clean this oven in accordance with the instructions.
- The oven should be kept clean at all times. A build-up of fats or other foodstuffs could result in a fire, especially in the grill pan.
- Always allow the oven to cool down and switch off the electrical supply before carrying out any cleaning or maintenance work.

Service

- This oven should only be repaired or serviced by an authorised Service Engineer and only genuine approved spare parts should be used.

Environmental Information

- After installation, please dispose of the packaging with due regard to safety and the environment.
- When disposing of an old appliance, make it unusable, by cutting off the cable. Remove any door catches, to prevent small children being trapped inside.

Keep this instruction book for future reference and ensure it is passed on to any new owner.

Contents

For the User

| | | |
|---|-------------|-----------|
| Important safety information | Page | 2 |
| Description of the oven | Page | 4 |
| Control Panel | Page | 5 |
| The Electronic Programmer Display | Page | 6 |
| How to Select a Cooking Function and Temperature | Page | 7 |
| How to switch off the oven | Page | 7 |
| How to Set The Programmer | Page | 9 |
| Child Safety | Page | 10 |
| Meat Probe | Page | 11 |
| Before the First Use | Page | 13 |
| Using the Oven | Page | 13 |
| The Fan Oven | Page | 14 |
| The Conventional Oven | Page | 17 |
| Cooking Chart | Page | 18 |
| Defrosting | Page | 19 |
| Grilling | Page | 20 |
| Pizza Oven | Page | 23 |
| Bread Proving | Page | 23 |
| Cleaning the Oven | Page | 24 |

| | | |
|------------------------------------|-------------|-----------|
| Grease Filter | Page | 25 |
| Care of Catalytic Liners | Page | 26 |
| Replacing the Oven Light | Page | 26 |
| Cleaning the hinged Grill | Page | 27 |
| If something goes wrong | Page | 28 |
| Service and Spare Parts | Page | 29 |
| Peace of Mind for 24 months | Page | 29 |

For the Installer

| | | |
|------------------------------|-------------|-----------|
| Technical Data | Page | 30 |
| Electrical Connection | Page | 30 |
| Building In | Page | 31 |

Guide to Use the instructions

The following symbols will be found in the text to guide you throughout the Instructions:



Safety Instructions



Step by step instructions for an operation



Hints and Tips



This appliance complies with the following E.E.C. Directives:

- * 73/23 - 90/683 (Low Voltage Directive);
- * 93/68 (General Directives);
- * 89/336 (Electromagnetical Compatibility Directive) . and subsequent modifications

Description of the Oven

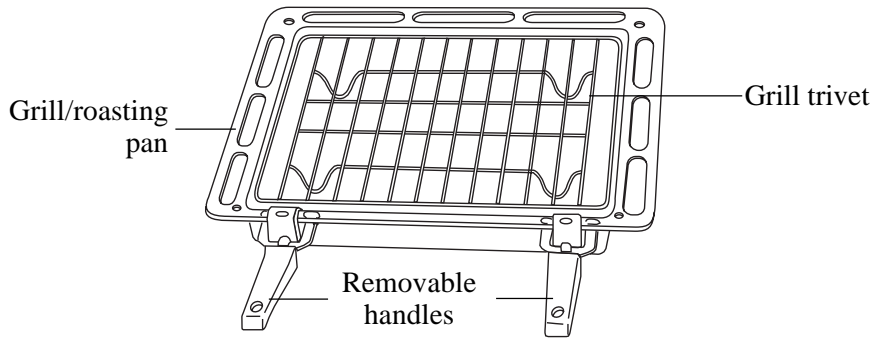
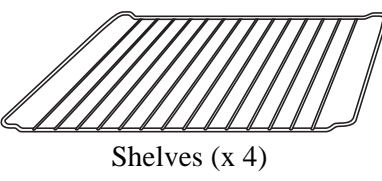
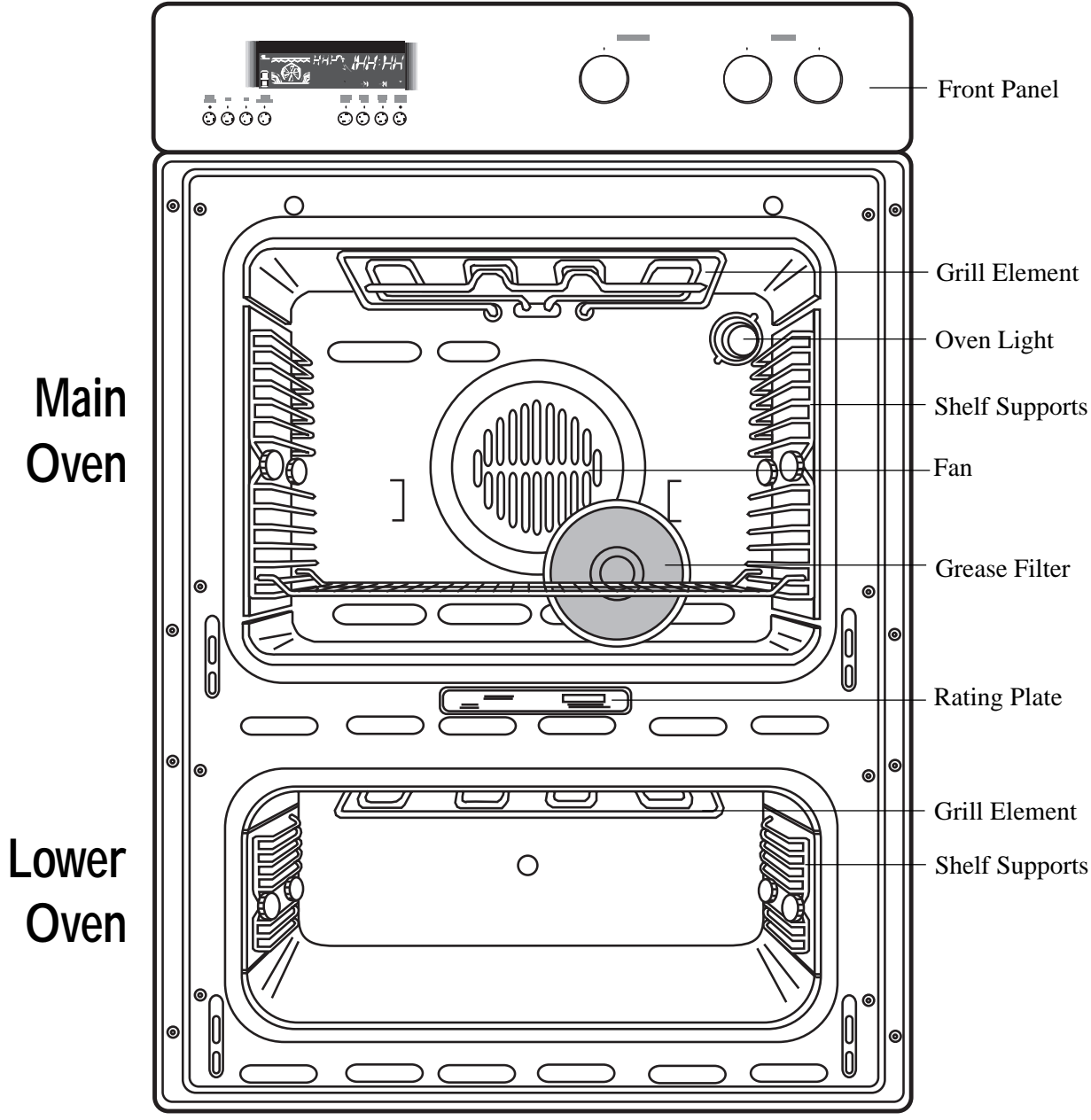

Control Panel

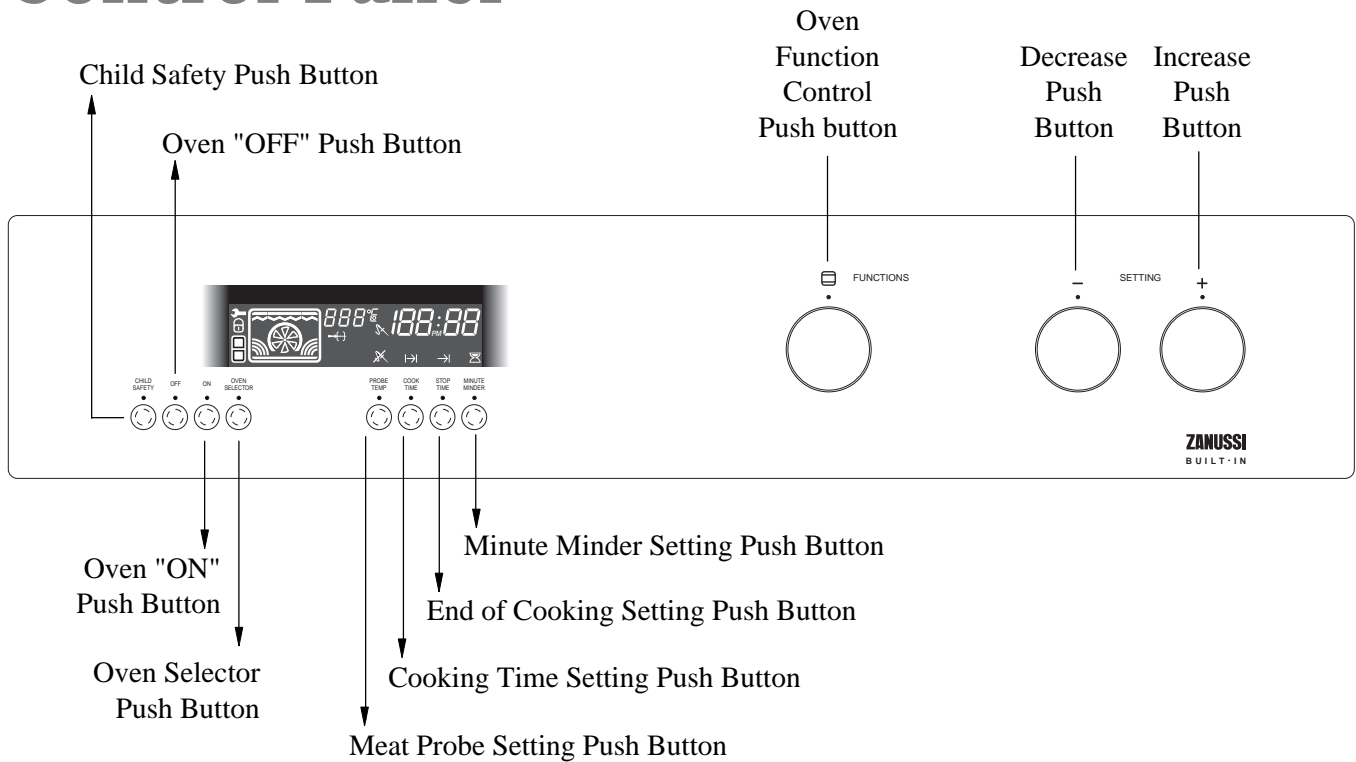

Oven "ON" Push Button

The oven must be switched on before setting any cooking function or programme.

When the "ON" push button is pressed, the programmer display will show . This means that the main oven has been automatically selected.

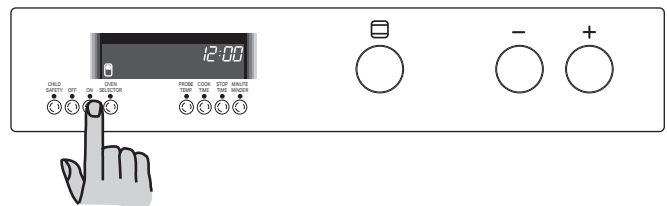

Oven "OFF" Push Button

To switch off the oven, press the "OFF" push button. Any cooking function or programme will stop, the oven light will go off, and the programmer display will show the time of day.

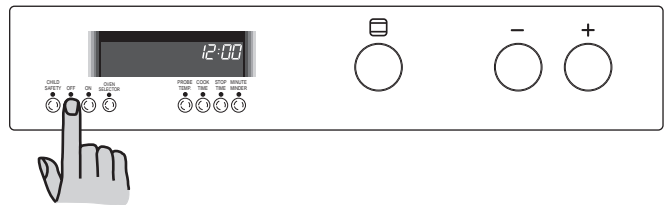

Oven Selector Push Button

To select the main oven or the lower oven, press the "Oven Selector" push button.

When the symbol is displayed, the main oven is selected. When the symbol is displayed, the lower oven is selected.

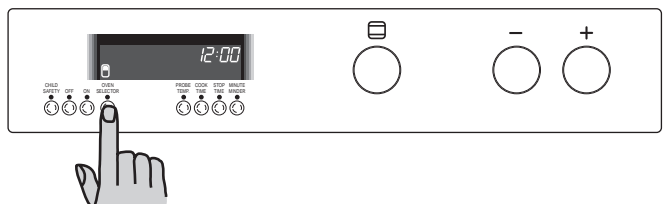

Oven Function Control Push Button

This large push button marked with allows you to select the cooking function. When the oven is switched on the main oven will automatically be selected. Each time you push this button, the symbol on the programmer display will change, showing what cooking function has been chosen.

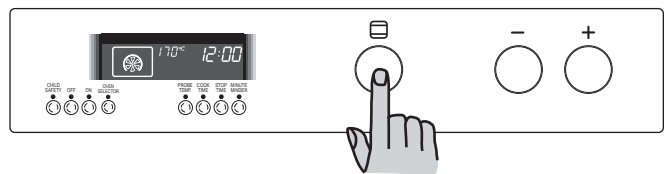

Increase and Decrease Push Buttons

The large buttons marked with plus (+) and minus (-) allow you to increase or decrease temperatures or time settings.

The Electronic Programmer Display

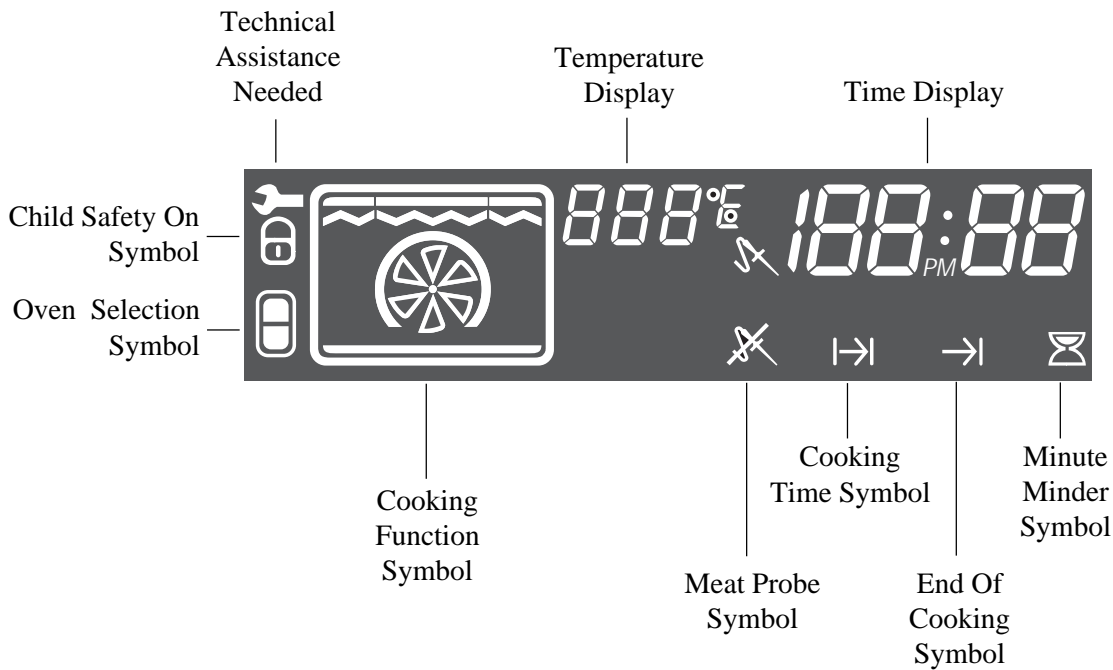

All the oven functions are controlled by an electronic programmer.

You can select any combination of cooking function, cooking temperature and automatic timing.

i In the event of a power failure, all the settings (time of day, program setting or program in operation), will be cancelled. When the power is restored, the numbers on the display will flash, and the clock-timer has to be reset.

How to set the Time of Day

The oven has a 24 hour clock.

When the oven is first connected to the electrical supply, the display will automatically show 12:00.

To set the correct time of day:

- 1) press the "Cook Time" and the "Stop Time" buttons at the same time,
- 2) release the buttons
- 3) **within 3 seconds**, press either the "Decrease" or "Increase" large push buttons, until the time of day is displayed. If no button is pressed within 3 seconds, the clock will automatically revert back to 12:00

NOTE: In the event of a power failure, the clock will revert to 12:00 and will require resetting.

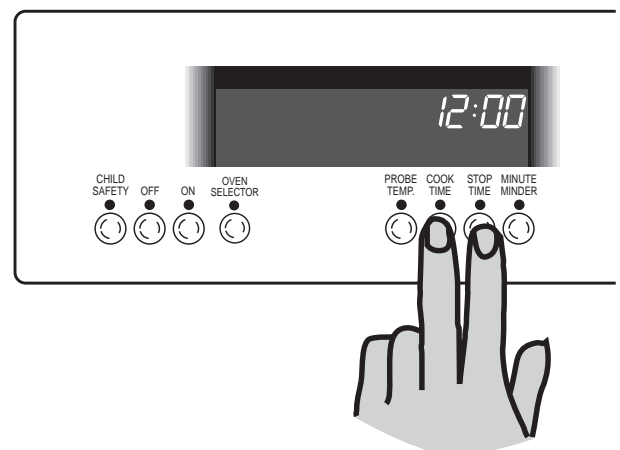

How to select a Cooking Function and Temperature

The main oven has 10 different cooking functions. The lower oven has four cooking functions. For each of them, a pre-set temperature will be automatically selected.

- 1) Switch on the oven by pressing the "ON" button. The symbol  will come on to indicate that the main oven has been selected. To change the oven selection press the "Oven Selector" push button.
- 2) Press the Oven Function Control button until the required function is shown on the display.
- 3) If the pre-set temperature is not suitable, select the required temperature using the "Increase" or "Decrease" buttons.

After a few seconds, the temperature display will show the current temperature of the oven cavity.

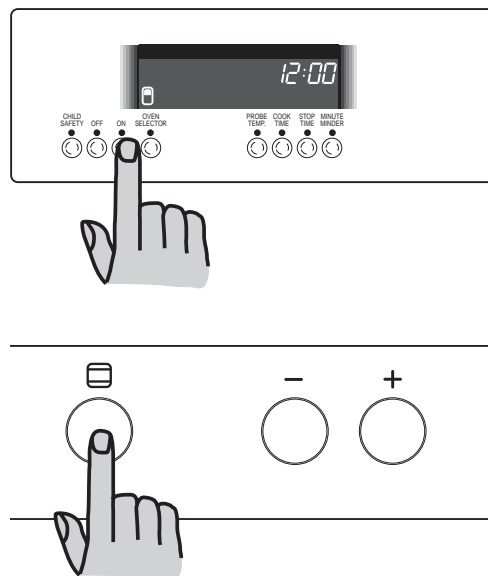

How to switch off the oven

To switch off the oven, press the "OFF" push button. Any cooking function or programme will stop, the oven light will go off, and the programmer display will show the time of day.

i If both ovens are in use, pressing the "OFF" button will switch off both the ovens.

If both ovens are in use and you wish to switch off one only, proceed as follows:

- 1) Press the Oven Selector button to select the oven to be switched off.
- 2) Press the Oven Function Control push button repeatedly until the function display is blank.
- 3) After a few seconds, the selected oven will switch off and the function display will revert to the other oven.

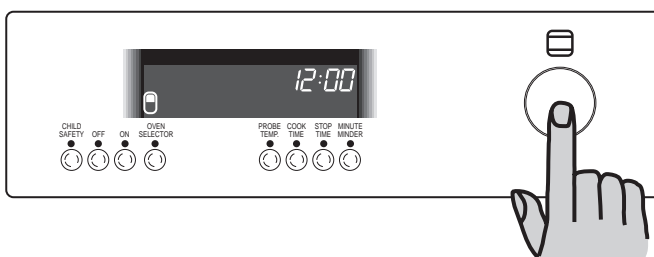
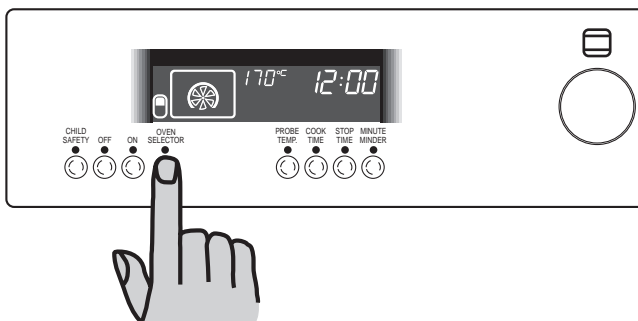
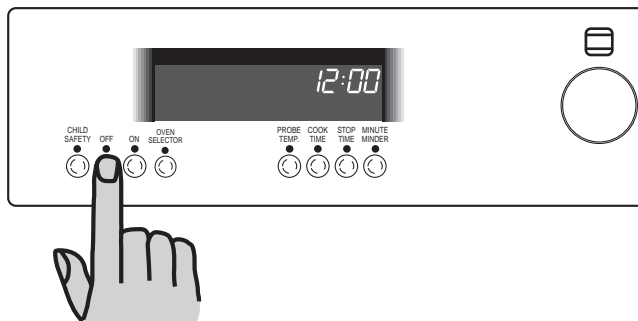

Main Oven Cooking Function Symbols



Fan cooking - This allows you to roast or roast and bake simultaneously using any shelf, without flavour transference.



Conventional cooking - The heat comes from both the top and bottom element, ensuring even heating inside the oven.



Grill - The full grill element will be on.



Inner grill element only - Useful for grilling small quantities.



Thermal Grilling - The grill element and the oven fan operate together, circulating hot air around the food.



Pizza Oven - Recommended for pizzas, quiches or pies.



Top heating element - The heat comes from the top of the oven only.



Bottom heating element - The heat comes from the bottom of the oven only.



Bread Proving - To shorten the proving time of bread, pizza dough, etc.



Defrost Setting - This setting is intended to assist in thawing of frozen food.

Lower Oven Cooking Function Symbols



Conventional cooking - The heat comes from both the top and bottom element, ensuring even heating inside the oven.



Top heating element - The heat comes from the top of the oven only.



Grill - The full grill element will be on.



Inner grill element only - It can be used for grilling small quantities.

How to set the minute minder

- 1) Press the "Minute Minder" button. The symbol  will be displayed and the time display will show ":00".
- 2) Use the "Increase" or "Decrease" buttons to enter the required time.

At the end of the timed period, an alarm will sound. To switch off the alarm press the "Minute Minder" button.

Note: the Minute Minder function will not switch off the oven, if in use.

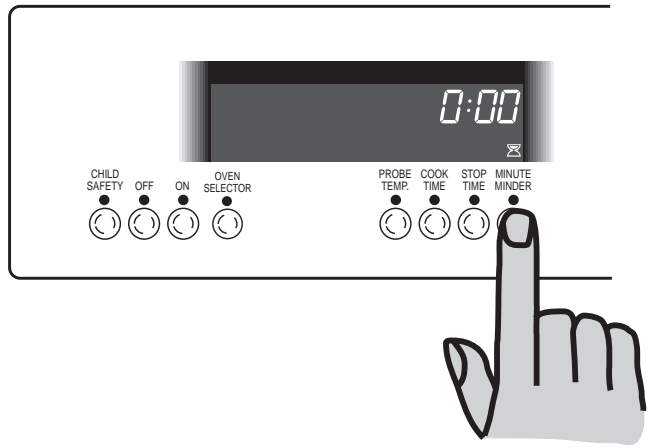

How to programme the oven to switch off only

This is useful if you want to begin cooking immediately but have the oven switch off automatically.

1. Place food in the oven.
2. Switch the oven on, then select the required oven, cooking function and temperature (see previous page).
3. Press the "Cook Time" button. The symbol  will come on and the time display will show ":00".
4. Use the "Increase" or "Decrease" buttons to enter the required time. The diagram shows the programmer set for 30 minutes.

At the end of the cooking time the oven will switch off and an alarm will sound. To switch off the alarm press the "OFF" button.

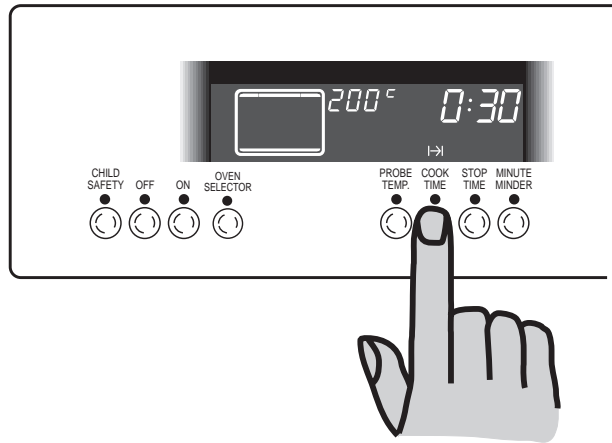

How to programme the oven to switch on and off

1. Ensure the clock is showing the right time of day.
2. Carry out steps 1 to 4 as explained in "How to programme the oven to switch off only"
3. Press the "Stop Time" button. The symbol  will come on and the time display will show the time of day.
4. Use the "Increase" or "Decrease" buttons to enter the time when you want the oven to switch off. The diagram shows the oven set to switch off at half past noon.

The oven will switch on automatically at the required time. E.g. if you set the cooking time at 1 hour and the stop time at 7:30 p.m., the oven will switch on at 6:30 p.m. At the end of the cooking time the oven will switch off and an alarm will sound. To switch off the alarm press the "OFF" button.

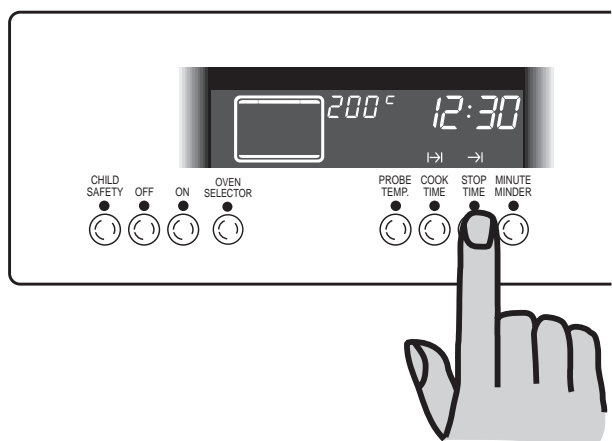

Automatic switch off

Should you forget to switch the oven off after a programme, or if the "ON" button is pressed accidentally, the oven will switch off automatically. In the case of manual functioning, the programmer will switch the oven off automatically if no other button is activated after a certain time. This time varies according to the temperature setting of the oven, and ranges from a minimum of 2 hours for temperatures above 230°C, up to 8 hours for those below 120°C.

At the end of automatic cooking, the oven will switch off after a period of time, this depends on the temperature selected.

The time varies between 2 hours for temperatures above 230°C, up 8 hours for those below 120°C.

Child Safety

To avoid children altering a selected programme or temperature, the Child Safety facility can be operated.

Press the "Child Safety" button and the "Oven On" button at the same time and keep them pressed for approximately 5 seconds.

The padlock symbol  will be displayed.

It is now only possible to select any programme while simultaneously pressing the "Child safety" button.

To cancel the Child Safety Feature, press the "Oven On" button. Then press button the "Child Safety" button and the "Oven OFF" button at the same time and keep them pressed for approximately 5 seconds. The padlock symbol will disappear from the display.

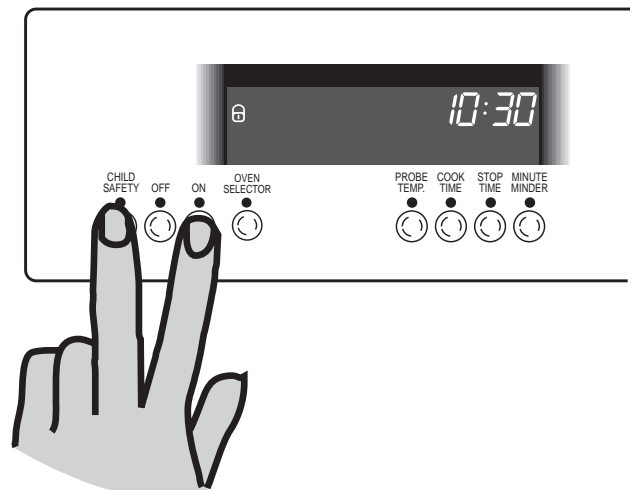

Call for technical assistance

The programmer display carries out a self check, in order to verify that it is working correctly. If a problem is identified the spanner symbol will be displayed and in the event of a breakdown a NUMBER will appear. If NUMBERS 001 or 002 appear it means that the meat probe is at fault and needs to be replaced; if a higher number appears, please contact your nearest Zanussi Service Force Centre **quoting the number of Fault Code.**

NOTE:

Generally after about 8 seconds from pressing a function button the programmer will allow the selected function to operate. Should another button be pressed during the operation of a function, the display will show momentarily details of the function in progress. For the new command to be accepted it will be necessary to press the other button again.

Meat Probe (Main Oven only)

The meat probe is a feature which will control the cooking of meat by informing you of the exact temperature at the centre of the meat. It is not necessary to weigh the meat, the sensor determines the cooking time. The cooking time will be influenced by the cooking temperature.

The probe consists of a skewer like sensor at one end of a heat resistant cable, and a plug at the other end.



Only use the meat probe supplied with the oven or an original spare part.

- 1) First raise the meat probe socket cover (1), which is located in the top of the left hand side of the oven and plug the probe connecting pin into its socket (2).
- 2) Insert the probe sensor into the centre of the meat, taking care to avoid touching any bone or pockets of fat as this will give a false temperature reading.
- 3) Place the meat, in a suitable tin, into the oven cavity.
- 4) To select the Meat Probe function press the "Probe Temp." button. The display will show the pre-set temperature of 60°C and the C symbol will flash for about 8 seconds.
- 5) Then select the finished internal meat temperature by pressing buttons **+** or **-**. Check the recommended temperatures in the roasting chart for meat probe function.
- 6) Select the required cooking function by pressing button .

i Not all the cooking functions allow the use of the probe (see next page). If you have selected an incorrect function, the probe symbol will flash red. For a correct function, the symbol will flash white.

- 7) The probe will then continue to register the internal meat temperature throughout the cooking period and convey the information to the programmer. The programmer will give a visual read-out as cooking continues, and switch off the oven when the selected temperature has been reached.
- 8) Press the "OFF" button to turn the oven off.
- 9) Open the oven door and remove the probe from the meat, then remove the probe from the socket.

i As poultry is a difficult shape with a great deal of bone it is difficult to register a correct finish temperature. Please ensure it is cooked thoroughly.

Do not submerge the meat probe in water, just wipe with a clean damp cloth.

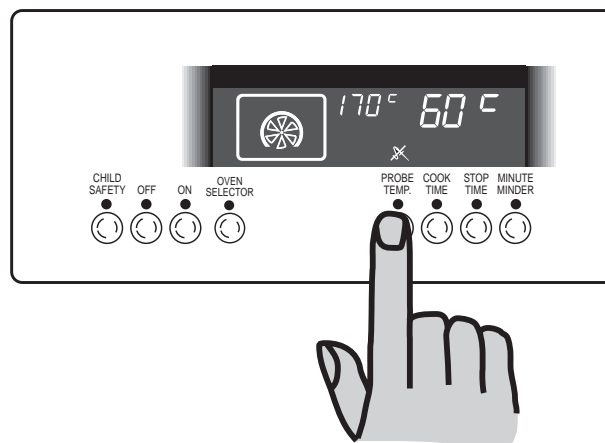
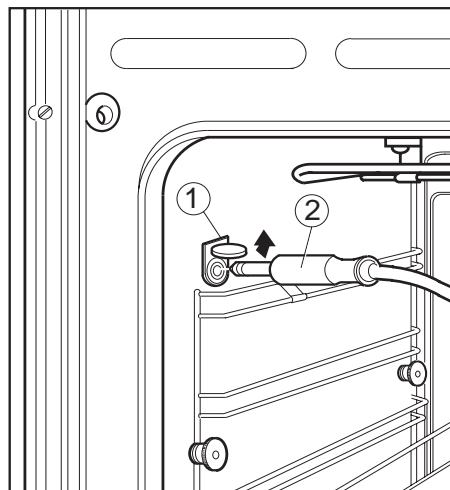

| Roasting Chart - Meat probe Function | | |
|--------------------------------------|-----------------------|------|
| Type of meat | Internal Temperatures | |
| Pork | Well done | 80°C |
| Lamb | Medium | 70°C |
| | Well done | 80°C |
| Beef | Rare | 60°C |
| | Medium | 70°C |
| | Well done | 80°C |
| Chicken | Well done | 82°C |

The temperatures quoted above are given as a guide only.



Remove the meat probe after use.











Do not leave the meat probe in the oven when cooking other items.



If the oven has just been previously used and the interior is hot, it may not be possible to use the meat probe. In that case, upon selection of the Meat Probe function the symbol  will come on. Remove the meat probe from the oven and after a few minutes the Technical assistance symbol will disappear. You can either cook the meat without the probe or wait until the interior temperature of the oven has dropped down to 60°C.

Oven Functions and Programming Features

The following table lists the programming features available for each cooking function.

| OVEN FUNCTION | Meat Probe | Auto - Timer |
|--|----------------|----------------|
|  FAN OVEN | Main Oven only | Main Oven only |
|  CONVENTIONAL OVEN | Main Oven only | Yes |
|  GRILL | No | No |
|  ECONOMY GRILL | No | No |
|  THERMAL GRILLING | Main Oven only | Main Oven only |
|  PIZZA OVEN | No | Main Oven only |
|  TOP ELEMENT | Main Oven only | Yes |
|  BOTTOM ELEMENT | Main Oven only | Main Oven only |
|  BREAD PROVING | No | Main Oven only |
|  DEFROST COLD FAN | No | Main Oven only |

Should any of the programming features not be available for a particular cooking function, you will hear an audible signal.

Before the First Use





Remove **all packaging**, both inside and outside the oven, before using the oven.

Before first use, the oven should be heated without food. During this time, an unpleasant odour may be emitted. This is quite normal.



1. Switch on the oven by pressing the "ON" push button.
2. Select the Fan Oven Function  by pressing the Oven Function Control button.
3. Set the temperature to 250°C by means of the "Increase" button.
4. Open a window for ventilation.
5. Allow the oven to run empty for approximately 45 minutes.

This procedure should be repeated with the grill function  for approximately 5-10 minutes.

The lower oven should also be heated in the same way using both the conventional cooking function  and the grill function .

Using the Oven



- **Always cook with the oven door closed.**
- Stand clear when opening the drop down oven door. **Do not** allow it to fall open - support the door using the door handle, until it is fully open.



- The Main Oven has fourteen shelf levels, and is supplied with three shelves.

The Lower Oven has three shelf levels and is supplied with one shelf.

The shelf positions are casted from the bottom of the oven as shown in the diagram.

It is important that these shelves are correctly positioned as shown in the diagram.

- Do not place cookware directly on the oven base.

MAIN OVEN

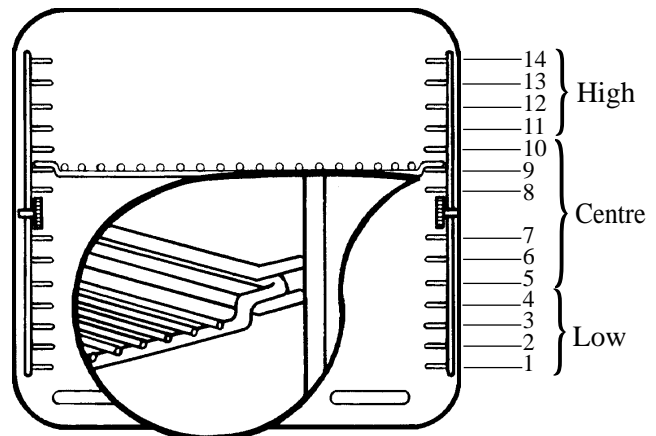

LOWER OVEN

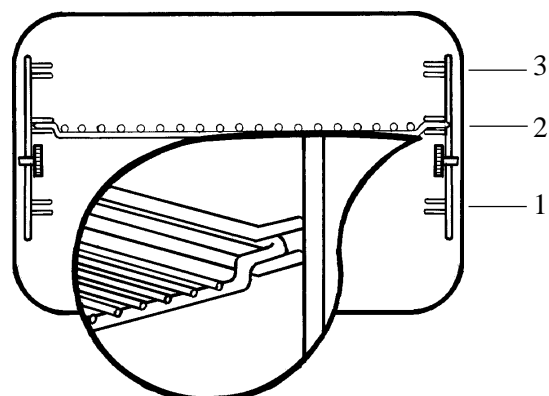

Hints and Tips

Condensation and steam

When food is heated it produces steam in the same way as a boiling kettle. The oven vents allow some of this steam to escape. However, **always stand back from the oven when opening the oven door** to allow any build up of steam or heat to release.

If the steam comes into contact with a cool surface on the outside of the oven, e.g. a trim, it will condense and produce water droplets. This is quite normal and is not a fault with the oven.

To prevent discoloration, regularly wipe away condensation and also soilage from surfaces.

Cookware

- Use any oven proof cookware which will withstand temperatures of 250°C.
- Baking trays, oven dishes, etc. should not be placed directly against the grid covering the fan at the back of the oven, or placed on the oven base.
- Do not use baking trays larger than 30 cm x 35 cm (12 in x 14 in) as they will restrict the circulation of heat and may affect performance.

The effects of dishes on cooking results

Dishes and tins vary in their thickness, conductivity, colour, etc. which affects the way they transmit heat to the food inside them.

- A** Aluminium, earthenware, oven glassware and bright shiny utensils reduce cooking and underneath browning.
- B** Enamelled cast iron, anodized aluminium, aluminium with non-stick interior and coloured exterior and dark, heavy utensils increase cooking and underneath browning.

The Fan Oven (Main Oven only)

The air inside the oven is heated by the element around the fan situated behind the back panel. The fan circulates hot air to maintain an even temperature inside the oven.

The advantages of cooking with this function are:

✓ **Faster Preheating**

As the fan oven quickly reaches temperature, it is not usually necessary to preheat the oven although you may find that you need to allow an extra 5-7 minutes on cooking times. For recipes which require higher temperatures, best results are achieved if the oven is preheated first, e.g. bread, pastries, scones, souffles, etc.

✓ **Lower Temperatures**

Fan oven cooking generally requires lower temperatures than conventional cooking. Follow the temperatures recommended in the chart at page 18. Remember to reduce temperatures by about 20-25°C for your own recipes which use conventional cooking.

✓ **Even Heating for Baking**

The fan oven has uniform heating on all runner positions. This means that batches of the same food can be cooked in the oven at the same time. However, the top shelf may brown slightly quicker than the lower one. This is quite usual. There is no mixing of flavours between dishes.



1. Switch the oven on.
2. Press the Oven Function Control button once.
3. If necessary adjust temperature setting by means of the "Increase" or "Decrease" buttons.

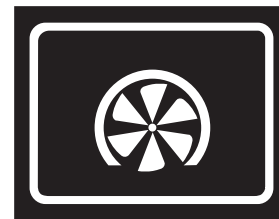
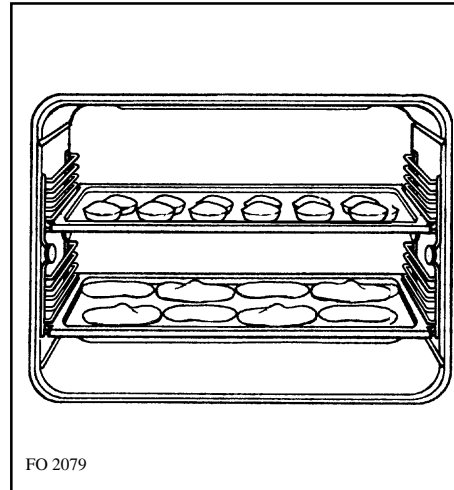

FAN OVEN FUNCTION SYMBOL
TEMPERATURE SELECTION: 50°C - 250°C
PRE-SET TEMPERATURE: 170°C

THINGS TO NOTE

- The oven light will come on when the oven is switched on.
- The cooling fan will operate continually during cooking. It may run on after the oven is switched off to keep the controls cool. This is quite normal.

NOTE

The action of the cooling fan will depend on how long the oven has been used and at what temperature. It may not switch in at all at lower temperature settings nor run on where the oven has only been used for a short time.

i Hints and Tips

Runner positions are not critical, but make sure the shelves are evenly spread.

When cooking more than one dish in the fan oven, place dishes centrally on the shelves rather than several dishes on one shelf.

When the oven is full, you may need to allow slightly longer cooking time.

A shelf may be placed on the floor of the oven. Place dishes on a shelf in this position rather than on the oven base, to allow air circulation around the food.

When the oven is full of the same food, e.g. equal trays of small cakes or equal size victoria sandwich cakes, then they will be cooked in the same time and removed from the oven together. When different sizes of trays or types of food, e.g. biscuits and cakes are cooked, they will not necessarily be ready together.

The fan oven can be used to heat foods through without thawing first, e.g. fruit tarts, mince pies, sausage rolls, and other small pastry items. Use a temperature of 190-200°C and allow 20-40 minutes (depending on the quantity of food in the oven).

The use of too high temperatures can cause uneven browning. Check with the recommendations for oven temperatures given in the cooking charts, but be prepared to adjust the temperature by 10°C if necessary. Remember to reduce temperatures by about 20-25°C for your own conventional recipes.

The meat tin **should not** be placed on a heated hotplate or burner as this may cause the enamel to crack.

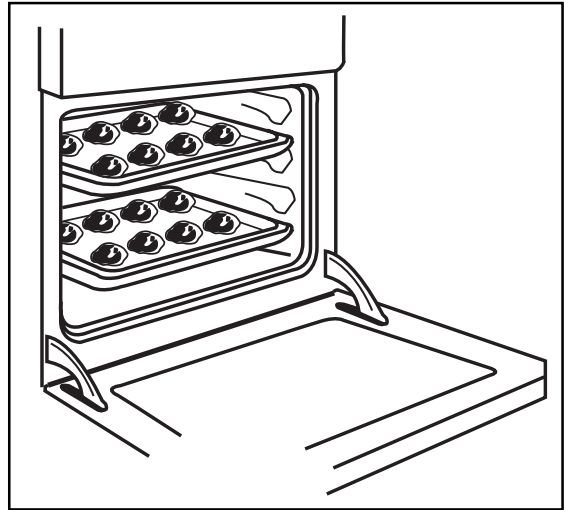

The Conventional Oven (Main and Lower Ovens)

When using this setting, heat comes from both the top and bottom elements. This allows you to cook in a single level and is particularly suitable for dishes which require extra base browning such as pizzas, quiches and flans.

Gratins, lasagnes and hotpots which require extra top browning also cook well in the conventional oven. This form of cooking gives you the opportunity to cook without the fan in operation.

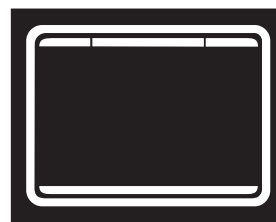

CONVENTIONAL OVEN FUNCTION SYMBOL
TEMPERATURE SELECTION: 50°C - 250°C
PRE-SET TEMPERATURE: 200°C

How to Use the Conventional Oven

1. Switch the oven ON and select the oven cavity.
2. Select the Conventional Oven Function by pressing the Oven Function control button until  appears on the display.

Top oven element only

This function is suitable for finishing cooked dishes, eg; lasagne, shepherds pie, cauliflower cheese etc.

Bottom oven element only

This function is particularly useful when blind-baking pastry or cooking pizza. It may also be used to finish off quiches or flans to ensure the base pastry is cooked through. **Please note that only the Main Oven can be set on this function.**

THINGS TO NOTE

During cooking, the cooling fan will operate in the same way as described for the fan oven function.

Hints and Tips

The middle shelf position allows for the best heat distribution. To increase base browning simply lower the shelf position. To increase top browning, raise the shelf position.

The material and finish of the baking trays and dishes used will affect base browning. Enamelware, dark, heavy or non-stick utensils increase base browning, while oven glassware, shiny aluminium or polished steel trays reflect the heat away and give less base browning.

Always place dishes centrally on the shelf to ensure even browning.

Stand dishes on suitably sized baking trays to prevent spillage onto the base of the oven and make cleaning easier.

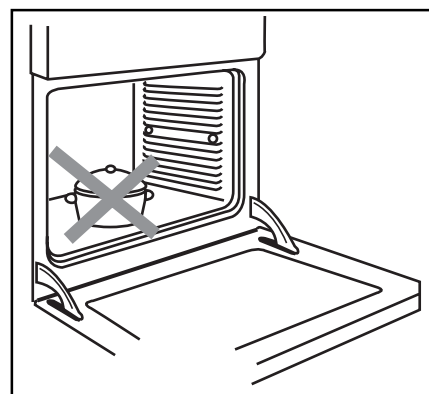
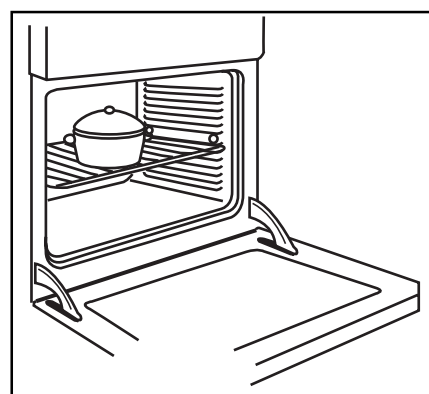

Do not place dishes, tins or baking trays directly on the oven base as it becomes very hot and damage will occur.



For faster preheating use the fan oven function to preheat the oven until the oven indicator neon goes out, then switch the selector to the conventional oven setting.

Single level cooking gives best results. If you require more than one level cooking use the fan oven function.

Cooking Chart - Fan and Conventional Oven

The oven temperatures are intended as a guide only. It may be necessary to increase or decrease the temperatures by 10 °C to suit individual preferences and requirements.

NOTE: Shelf positions are counted from bottom of the oven and are intended for the Main Oven only. When using the Lower Oven, please note that temperature and shelf positions must be adjusted according to type of food, its thickness and its weight.

| Food |  Fan Oven | |  Conventional Oven | |
|--|---|-------------------|--|-------------------|
| | Shelf Position | Cooking Temp (°C) | Shelf Position | Cooking Temp (°C) |
| Biscuits | | 180-190 | 6 - 9 | 180-190 |
| Bread | | 210-220 | 4 - 7 | 210-220 |
| Casseroles | | 130-140 | 4 - 7 | 150-180 |
| Cakes: Small and queen | Shelf positions are not critical but ensure that oven shelves are evenly spaced when more than one is used. | 160-170 | 4 - 7 | 170-180 |
| Sponges | | 160-170 | 4 - 7 | 180-190 |
| Madeira | | 140-150 | 4 - 7 | 160-170 |
| Rich Fruit | | 130-140 | 4 - 7 | 150-160 |
| Christmas | | 130-140 | 1 - 4 | 130-140 |
| Meringues | | 90-100 | 4 - 7 | 100-110 |
| Fish | | 170-190 | 4 - 7 | 170-190 |
| Fruit Pies and Crumbles | | 190-200 | 4 - 7 | 190-200 |
| Milk Puddings | | 130-140 | 4 - 7 | 130-140 |
| Pastry: Choux } Shortcrust } Flaky } Puff } | | 190-200 | 4 - 7 | 160-170 |
| Plate Tarts | 180 | 1 - 4 | 190-200 | |
| Quiches/Flans | 170-180 | 1 - 4 | 190-200 | |
| Scones | 210-220 | 4 - 7 | 230 | |
| Roasting: Meat & Poultry | 160-180 | 4 - 7 | 180-200 | |

Defrosting (Main Oven only)

The oven fan operates without heat and circulates the air, at room temperature, inside the oven. This increases the speed of defrosting. However, please note that the temperature of the kitchen will influence the speed of defrosting.

This function is particularly suitable for delicate food which could be damaged by heat, e.g. cream filled gateaux, iced cakes, pastries, bread and other yeast products.

How to Use Defrosting

1. Switch the oven ON
2. Press the Cooking Function Control Knob until  appears on the display.

Hints and Tips

- Cover food with a lid, aluminium foil or plastic film to prevent drying out during defrosting.
- ALWAYS COOK THOROUGHLY IMMEDIATELY AFTER THAWING.
- Frozen food should be placed in a single layer when ever possible and turned over half way through the defrosting process.
- Only joints of meat and poultry up to 2 kg. (4 lb.) are suitable for defrosting in this way.

Refer to the following table for approximate defrosting times.

| Food | Defrosting time (Mins) | Standing time (Mins) | Notes |
|---------------------|------------------------|----------------------|--|
| Chicken 1000 g. | 100-140 | 20-30 | Place the chicken on an inverted saucer on a large plate. Defrost open and turn at half time or defrost covered with foil. Remove giblets as soon as possible. |
| Meat 1000 g. | 100-140 | 20-30 | Defrost open and turn at half time or cover with foil |
| Meat 500 g. | 90-120 | 20-30 | As above |
| Trout 150 g. | 23-35 | 10-15 | Defrost open |
| Strawberries 300 g. | 30-40 | 10-20 | Defrost open |
| Butter 250 g. | 30-40 | 10-15 | Defrost open |
| Cream 2 x 200 g. | 80-100 | 10-15 | Defrost open (cream is easy to whip even if parts of it are still slightly frozen) |
| Cake 1400 g. | 60 | 60 | Defrost open |

The times quoted in the chart should be used as a guide only, as the speed of defrosting will depend on the kitchen temperature. For example, the colder the ambient temperature, the longer the defrosting time.

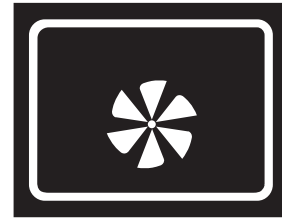

**DEFROSTING FUNCTION SYMBOL
PRE-SET TEMPERATURE: 40°C
TEMPERATURE SETTING CANNOT BE
CHANGED**

Grilling (Main and Lower ovens)



Grilling must be carried out with the oven door closed. The grill pan handles must be removed from the pan.



How to Use the Grill

1. Switch the oven ON and select the oven cavity
2. Press the Cooking Function Control Button until  appears on the display.
3. If necessary, press the "Increase" or the "Decrease" buttons to adjust the temperature setting.
4. Adjust the grid and grill pan runner position to allow for different thicknesses of food. Position the food close to the element for faster cooking and further away for more gentle cooking.

Preheat the grill on a full setting for a few minutes before sealing steaks or toasting. Adjust the heat setting and the shelf as necessary, during cooking

During cooking, the cooling fan and the thermostat control light will operate in the same way as described for the fan oven function.

Hints and Tips

- Most foods should be placed on the grid in the grill pan to allow maximum circulation of air to lift the food out of the fats and juices. Food such as fish, liver and kidneys may be placed directly on the grill pan, if preferred.
- Food should be thoroughly dried before grilling to minimise splashing. Brush lean meats and fish lightly with a little oil or melted butter to keep them moist during cooking.
- Accompaniments such as tomatoes and mushrooms may be placed underneath the grid when grilling meats.
- When toasting bread, we suggest that the top runner position is used.
- The food should be turned over during cooking, as required.

The grill element is controlled by the thermostat. During cooking, the grill cycles on and off to prevent overheating.



**GRILLING FUNCTION SYMBOL
TEMPERATURE SELECTION 50°C - 250°C
PRE-SET TEMPERATURE: 250°C**

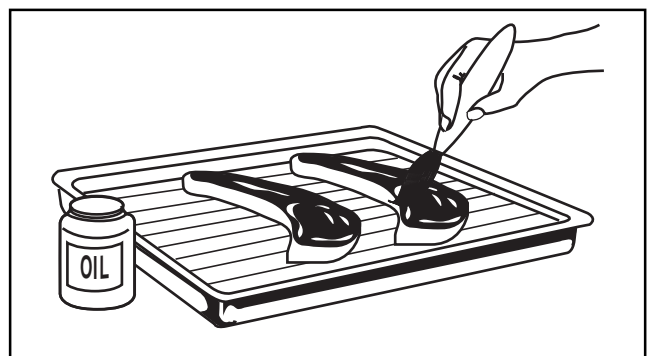

How to Use the Inner Grill Element

The inner grill provides quick direct heat to the central area of the grill pan. By using the inner grill element for cooking small quantities, it can help to save energy.

1. Switch the oven ON and select the oven cavity.
2. Press the Cooking Function Control Button until  appears on the display.
3. If necessary, press the "Increase" or the "Decrease" buttons to adjust the temperature setting.
4. Adjust the grid and grill pan runner position to allow for different thicknesses of food and follow the instructions for grilling.



INNER GRILL ELEMENT SYMBOL
TEMPERATURE SELECTION 50°C - 250°C
PRE-SET TEMPERATURE: 250°C

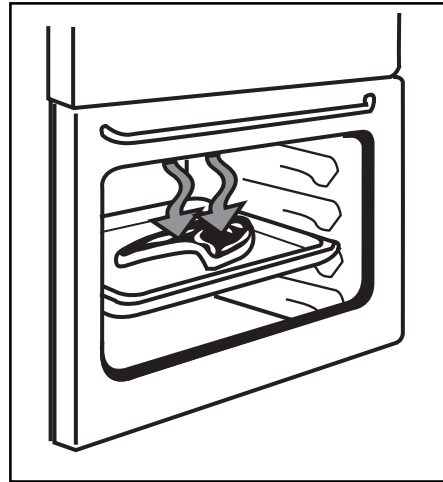

How to Use the Thermal Grill (Main Oven Only)

Thermal grilling offers an alternative method of cooking food items normally associated with conventional grilling. The grill element and the oven fan operate alternately, circulating hot air around the food. The need to check and turn the food is reduced. Thermal grilling helps to minimize cooking smells in the kitchen.

With the exception of toast and rare steaks, you can thermally grill all the foods you would normally cook under a conventional grill. Cooking is more gentle, therefore food generally takes a little longer to cook with thermal grilling compared with conventional grilling. One of the advantages is that larger loads can be cooked at the same time.

1. Switch the oven ON.
2. Press the Cooking Function Control Button until  appears on the display.
3. If necessary, press the "Increase" or the "Decrease" buttons to adjust the temperature setting.
4. Adjust the grid and grill pan runner position to allow for different thicknesses of food and follow the instructions for grilling.

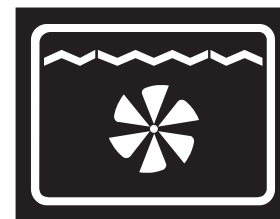

THERMAL GRILLING
TEMPERATURE SELECTION 50°C - 250°C
PRE-SET TEMPERATURE: 190°C
DO NOT EXCEED 200°C

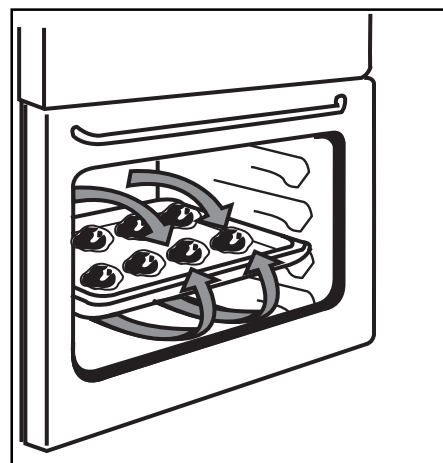



i Hints and Tips

Prepare foods in the same way as for conventional grilling. Brush lean meats and fish lightly with little oil or butter to keep them moist during cooking.

If thermally grilling on more than one level, it may be necessary to interchange the food on the shelves during cooking.

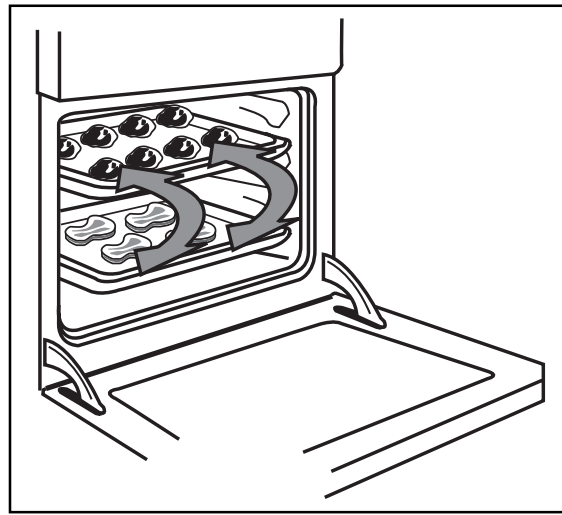
A general guide to cooking times is given below but these times may vary slightly depending on the thickness and quantity of food being cooked.



| Quantity Gr. | Pieces | TYPE OF COOKING |   GRILL - INNER GRILL | | | | |
|-----------------|--------|-----------------|--|--------------------|-------------|--------------------------|----------|
| | | | pre-heat minutes | shelf level (*) | Temp. °C | cooking time (in mins) * | |
| | | | | | | 1st side | 2nd side |
| 800 | 4 | Beef fillets | - | 11 - 13 | 250 | 8-10 | 4-6 |
| 600 | 4 | Pork chops | - | 11 - 13 | 250 | 8-10 | 5-8 |
| 800 | 8 | Spare ribs | - | 11 - 13 | 250 | 6-8 | 4-6 |
| 500 | 8 | Sausages | - | 11 - 13 | 250 | 8-10 | 4-6 |
| 700 | 4 | Kebabs | - | 11 - 13 | 250 | 10-12 | 5-7 |
| 500 | 4 | Chicken breasts | - | 11 - 13 | 250 | 10-12 | 5-7 |
| 500 | 6 | Sole | - | 11 - 13 | 250 | 6-8 | 4-6 |
| | 6 | Toast bread | - | 11 - 13 | 250 | 3-4 | 1-2 |

(*) The shelf positions are intended for the Main Oven only. When using the Lower Oven, please note that temperature and shelf positions must be adjusted according to type of food, its thickness and its weight.

| Quantity Gr. | Pieces | TYPE OF COOKING |  THERMAL GRILLING Select a maximum temperature of 200°C | | | | |
|-----------------|--------|--|---|----------------|-------------|--------------------------|----------|
| | | | pre-heat minutes | shelf level | Temp. °C | cooking time in (mins) * | |
| | | | | | | 1st side | 2nd side |
| 1000 | 2 | Rolled joints $\left\{ \begin{array}{l} \text{Beef} \\ \text{Lamb} \\ \text{Pork} \end{array} \right.$ | - | 9 - 10 | 180 | 30-40 | 20-30 |
| 800 | 4 | Quartered chicken | - | 9 - 10 | 200 | 25-30 | 15-20 |
| 1000 | 2 | Chickens | - | 9 - 10 | 190 | 30-35 | 25-30 |
| 800 | 1 | Guinea fowl | - | 6 - 7 | 180 | 35-40 | 30-35 |
| 500 | 2 | Pigeons | - | 9 - 10 | 180 | 35-40 | 30-35 |
| 500 | 4 | Quail | - | 9 - 10 | 200 | 25-30 | 20-25 |
| | | Vegetable gratin | - | 9 - 10 | 200 | 15-25 | - |
| | 4 | Toasted sandwiches | - | 9 - 10 | 200 | 3-5 | 1-2 |
| | 9 | St. Jacques shells | - | 9 - 10 | 200 | 15-20 | - |
| 600 | 2 | Mackerel | - | 9 - 10 | 200 | 10-20 | 6-8 |
| 800 | 4 | Fish slices | - | 9 - 10 | 200 | 10-15 | 8-10 |

(**) Food should be turned during cooking using these times as a guide

The times quoted above are given as a guide and should be adjusted to suit personal taste.



Pizza Oven (Main Oven only)

The bottom element provides direct heat to the base of pizzas, quiches or pies, while the fan ensure air is circulated to cook the pizza toppings or pie fillings. To obtain the best results use the lower shelf levels.

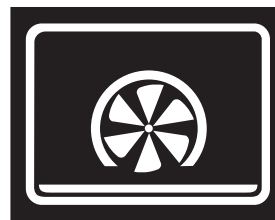
1. Switch the oven ON.
2. Press the Cooking Function Control Button until  appears on the display.
3. If necessary, press the "Increase" or the "Decrease" buttons to adjust the temperature setting.



PIZZA OVEN FUNCTION SYMBOL
TEMPERATURE SELECTION: 50°C - 250°C
PRE-SET TEMPERATURE: 220°C

| TYPE OF COOKING |  PIZZA OVEN | | Cooking time  minutes |
|------------------------|--|---------|--|
| | Shelf | Temp °C | |
| Pizza, large | 1 - 3 | 210-230 | 15-20 |
| Pizza, small | 1 - 3 | 200-220 | 10-20 |
| Quiche | 1 - 3 | 160-180 | 30-40 |
| Sweet Tart (treacle) | 1 - 3 | 170-180 | 20-30 |
| Place Fruit Tart | 1 - 3 | 170-180 | 25-30 |
| Blind Baked Flan Cases | 1 - 3 | 170-180 | 15-20 |
| Egg Custard Tart | 1 - 3 | 160-170 | 40-50 |



Bread Proving (Main Oven only)

This function has pre-set temperature of 40°C, which shortens the proving time of bread, pizza dough etc. This temperature setting can not be changed.

1. Switch the oven ON.
2. Press the Cooking Function Control Button until  appears on the display.



BREAD PROVING FUNCTION SYMBOL
PRE-SET TEMPERATURE: 40°C
TEMPERATURE SETTING CANNOT BE CHANGED

| TYPE OF COOKING |  BREAD PROVING | | Cooking time  minutes |
|-----------------------------|---|--------|--|
| | Note | Shelf | |
| Softening Butter | Loosen or remove wrapper | 4 - 7 | 15-30 |
| Drying Herbs | Arrange sprigs in a single layer | 4 - 7 | 20-30 |
| Warming sugar for Preserves | Spread out into a thin layer | 4 - 7 | 25-30 |
| Plate and Dish Warming | Do not place on base of oven | 6 - 9 | 15-20 |
| Drying Breadcrumbs | Sprinkle in a thin layer stir occasionally. | 9 - 10 | 40-50 |

Cleaning the Oven



Before cleaning always allow the cooling fan to cool the oven down before switching off at the electricity supply.

The oven should be kept clean at all times. A build-up of fats or other foodstuffs could result in a fire, especially in the grill pan.

Cleaning materials

Before using any cleaning materials on your oven, check that they are suitable and that their use is recommended by the manufacturer.

Cleaners that contain bleach should NOT be used as they may dull the surface finishes. Harsh abrasives should also be avoided.

External cleaning

Regularly wipe over the control panel, oven door and door seal using a soft cloth well wrung out in warm water to which a little liquid detergent has been added.



To prevent damaging or weakening the door glass panels avoid the use of the following:

- Household detergent and bleaches
- Impregnated pads unsuitable for non-stick saucepans
- Brillo/Ajax pads or steel wool pads
- Chemical oven pads or aerosols
- Rust removers
- Bath/Sink stain removers

Clean the outer and inner door glass using warm soapy water. Should the inner door glass become heavily soiled it is recommended that a cleaning product such as Hob Brite is used. Do not use paint scrapers to remove soilage.



DO NOT clean the oven door while the glass panels are warm. If this precaution is not observed the glass panel may shatter.

If the door glass panel becomes chipped or has deep scratches, the glass will be weakened and must be replaced to prevent the possibility of the panel shattering. Contact your local Service Centre who will be pleased to advise further.

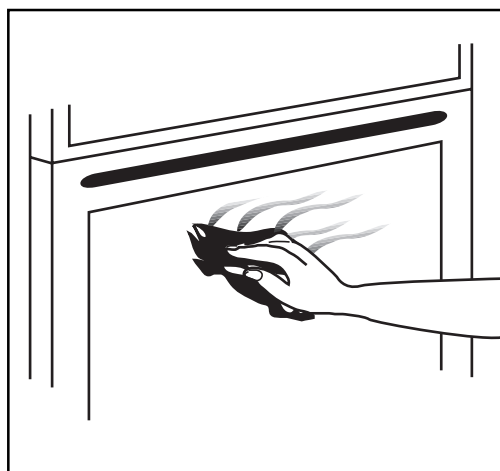

Oven Cavity

The enamelled base of the oven cavity is best cleaned whilst the oven is still warm.

Wipe the oven over with a soft cloth soaked in warm soapy water after each use. From time to time it will be necessary to do a more thorough cleaning, using a proprietary oven cleaner.

i DO NOT attempt to clean catalytic liners

Oven Shelves and Shelf Supports

To clean the oven shelves and the shelf supports, soak in warm soapy water and remove stubborn marks with a well wetted soap impregnated pad. Rinse well and dry with a soft cloth.

The shelf supports can be removed for easy cleaning (see diagram). Please, ensure the retaining nuts are secure when refitting the shelf support.

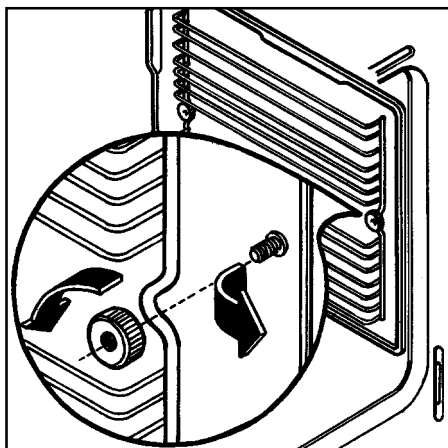

Grease Filter

To prevent a build-up of fats on the fan impellor, the grease filter must be fitted by clipping it over the vents in the back panel.

To clean the grease filter

When the oven has cooled down, remove the filter by pushing the protruding tongue on the filter upward, and wash carefully.

The grease filter should be cleaned after every use. The filter may be washed in a dishwasher on a 65°C wash. If the filter is heavily soiled, place the filter in a saucepan of water with approximately 1 teaspoon of automatic washing powder or dishwasher powder. Bring to the boil and leave to soak for approximately 30 minutes or longer depending on the degree of soiling. Ensure the solution does not boil over as it could mark your hob.

Rinse filter in clear water and dry.

Remember to refit the filter before using the oven again.

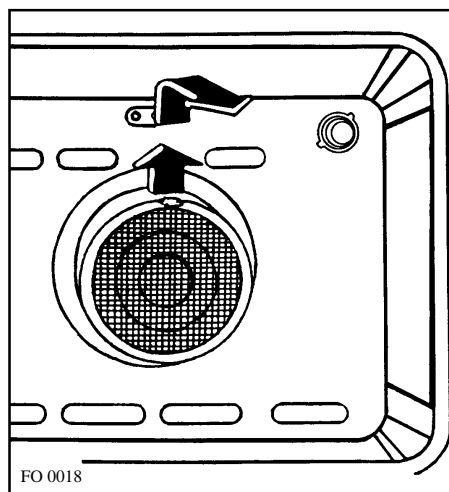

Care of catalytic liners (Main Oven only)

Catalytic liners destroy splashes of food and fats when the oven temperature is raised to around 220°C. To aid this process it is a good idea to run the oven for an hour or two per week, without food, to ensure continued good performance from the Catalytic liners.

Hints and Tips

- Manual cleaning of the Catalytic liner is not recommended. Damage will occur if soap impregnated steel wool pads, aerosol cleaners and any other abrasives are used.
- Slight discoloration and polishing of the Catalytic surface may occur in time. This does not affect the Catalytic properties in any way.
- Follow the recommendations below to keep oven soilage to a minimum.

COOKING TO REDUCE SOILAGE

Cook at the recommended temperatures. Higher temperatures during roasting will increase soilage. Try cooking to lower temperatures for an increased length of time, you will save energy and often the joint is more tender.

Use minimal, if any, extra oil or fat when roasting meat; potatoes only require brushing with fat before cooking. Extra fat in the oven during roasting will increase splashing and soilage.

It is NOT necessary to add water to the meat tin when roasting. The water and the fat juices from the joint create excessive splattering during cooking, even at normal temperatures, as well as causing condensation.

Covering joints during cooking will also prevent splashing onto the interior surfaces; removing the covering for the last 20-30 minutes will allow extra browning, if required. Some large joints and turkeys especially benefit by this method of cooking, allowing the joint to cook through before the outside is overbrowned.

Do use the roasting tin. During roasting, the fat from the joint will be contained beneath the trivet and therefore prevent it from splattering onto the 'Catalytic' liner.

Replacing the Oven Light

If the oven bulb needs replacing, it must comply with the following specifications:

- Electric power: 15W,
- Electric rate: 230-240 V (50 Hz),
- Resistant to temperatures of 300°C,
- Connection type: E14.

These bulbs are available from your local Zanussi Force Service Centre.



To replace the faulty bulb:

1. Ensure the oven is isolated from the electrical supply.
2. Turn the glass cover anticlockwise.
3. Remove the faulty bulb and replace with the new one.
4. Refit the glass cover.
5. Restore the electrical supply.

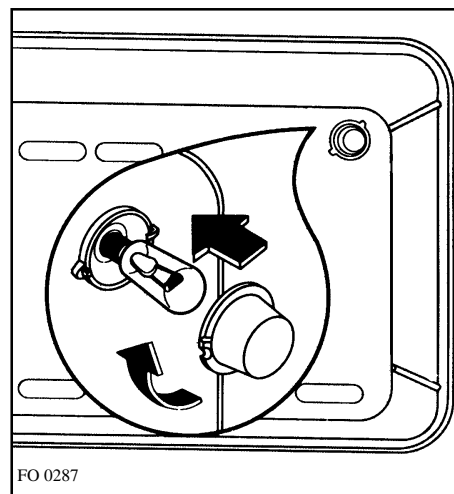

Cleaning the hinged grill

This model has been fitted with a hinged grill element to enable you to clean the roof of the oven easily.

 ***Before proceeding ensure the oven is cool and is isolated from the electricity supply.***

 1) Undo the screw which holds the grill in place (see diagram).

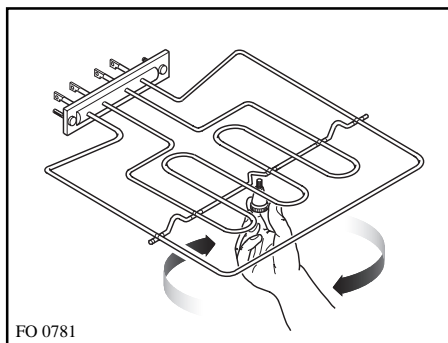

2) Then gently pull the grill downward to allow access to the oven roof (see diagram).

3) Clean the oven roof with a suitable cleaner and wipe dry before replacing the hinged grill element.

4) Gently push up the grill element into place and firmly screw into place the holding nut.

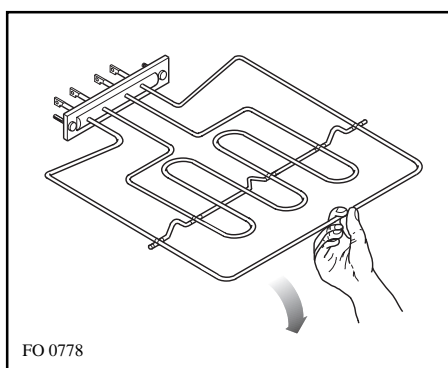

 ***Ensure the grill holding nut is firmly in place to avoid the grill falling down when in use***

If something goes wrong

If the oven is not working correctly, please carry out the following checks, before contacting your local Zanussi Service Centre.

IMPORTANT: If you call out an engineer to a fault listed below, or to repair a fault caused by incorrect use or installation, a charge will be made even if the appliance is under guarantee.

| SYMPTOM | SOLUTION |
|---|---|
| <ul style="list-style-type: none"> ■ The oven does not come on | <ul style="list-style-type: none"> ◆ Press the OVEN ON button, then select a cooking function. ◆ Check the oven is wired in properly, and the socket switch or the switch from the mains supply to the oven are ON. |
| <ul style="list-style-type: none"> ■ The oven light does not come on | <ul style="list-style-type: none"> ◆ Select a function with the oven function control knob ◆ Check the light bulb, and replace it if necessary (see "Replacing the Oven Light") |
| <ul style="list-style-type: none"> ■ It takes too long to finish the dishes, or they are cooked too fast. | <ul style="list-style-type: none"> ◆ The temperature may need adjusting ◆ Refer to the contents of this booklet, especially to the chapter "Using the Oven". |
| <ul style="list-style-type: none"> ■ Steam and condensation settle on the food and the oven cavity. ■ The timer does not work | <ul style="list-style-type: none"> ◆ Leave dishes inside the oven no longer than 15-20 minutes after the cooking is completed. See page 10 ◆ Check the instructions for the timer. |
| <ul style="list-style-type: none"> ■ The oven fan is noisy | <ul style="list-style-type: none"> ◆ Check the grease filter is correctly fitted. ◆ Check that shelves and bakeware are not vibrating in contact with the oven back panel. |

SELF CHECK FUNCTION

The programmer also carries out a self check, in order to verify that it is working correctly. If a problem is identified, the spanner symbol  will be displayed. In the event of a breakdown, a NUMBER will appear.

If numbers 001 or 002 appear, it means that the meat probe is at fault and needs to be replaced.

If the symbol  appears when you plug in the meat probe, ensure the interior of the oven does not exceed the pre-set temperature of the meat probe.

If a higher number appears, please contact your nearest Zanussi Service Force Centre.

When you contact them, they will need the following information:

1. Your name, address and post code.
2. Your telephone number
3. The model and the serial number (which can be found on the rating plate)
4. Clear and concise details of the fault, for example when does the fault occur and how often, or if shown on the programmer display, the fault code.
5. Date of purchase

Please note that it will be necessary to provide proof of purchase for any in-guarantee service calls.

In-guarantee customers should ensure that the above checks have been made as the engineer will make a charge if the fault is not a mechanical or electrical breakdown.

Service and Spare Parts



If you require spare parts or an engineer contact your local Service Force Centre by telephoning:

08705 929929

Your call will be routed to your local Service Force Centre. For further details, please see the accompanying Customer Care Booklet.

CUSTOMER CARE

For general enquiries concerning your Zanussi appliance, contact our Customer Care Department by letter or telephone as follows:

Customer Care Department

Zanussi
55-77 High Street
Slough, Berkshire, SL1 1DZ
Tel: 08705 - 727727

Peace of Mind for 24 Months

ZANUSSI GUARANTEE CONDITIONS

We, Zanussi, undertake that if, within 24 months of the date of the purchase, this Zanussi appliance or any part thereof is proved to be defective by any reason only of faulty workmanship or materials, we will, at our option, repair or replace the same **FREE OF ANY CHARGE** for labour, materials or carriage on condition that:

- * The appliance has been correctly installed and used only on the gas and electricity supply stated on the rating plate.
- * The appliance has been used for normal domestic purpose only, and in accordance with the manufacturer's instructions.
- * The appliance has not been serviced, maintained, repaired, taken apart or tampered with by any person not authorised by us.
- * All service work under this guarantee must be undertaken by a Zanussi Service Centre.
- * Any appliance or defective part replaced shall become the Company's property.
- * This guarantee is in addition to your statutory and other legal rights.

Home visits are made between **8.30am and 5.30pm** Monday to Friday. Visits may be available outside these hours, in which case a **premium** will be charged.

Exclusions

This guarantee does not cover:

- * Damage or calls resulting from transportation, improper use or neglect, the replacement of any light bulbs or removable parts of glass or plastic.
- * Costs incurred for calls to put right an appliance which is improperly installed or calls to appliance outside the European Community (EC) or European Free Trade Area.

- * Appliances found to be in use within a commercial or similar environment, plus those which are the subject to rental agreements.
- * Products of Zanussi manufacture which are not marketed by Zanussi.

European Guarantee

If you should move to another country within Europe then your guarantee moves with you to your new home subject to the following qualifications:

- * The guarantee starts from the date you first purchased your product.
- * The guarantee is for the same period and to the same extent for labour and parts as exist in the new country of use for this brand or range of products.
- * This guarantee relates to you and cannot be transferred to another user.
- * Your new home is within the European Community (EC) or European Free Trade Area.
- * The product is installed and used in accordance with our instructions and is only used domestically, i.e. a normal household
- * The product is installed taking into account regulations in your new country.

Before you move, please contact your nearest Customer Care centre, listed below, to give them details of your new home. They will then ensure that the local Service Organisation is aware of your move and able to look after you and your appliances.

| | | |
|---------|-----------|----------------------|
| France | Senlis | +33 (0)3 44 62 29 99 |
| Germany | Nürnberg | +49 (0)911 323 2600 |
| Italy | Pordenone | +39 (0)1678 47053 |
| Sweden | Stockholm | +46 (0)8 738 79 50 |
| UK | Slough | +44 (0)1753 219897 |

Installation



The oven must be installed according to the instructions supplied.



This oven must be installed by **qualified personnel** to the relevant British Standards.

| | | |
|-----------------------------|--------|-------------|
| DIMENSIONS OF RECESS | Height | 878 mm. |
| | Width | 560-570 mm. |
| | Depth | 550 mm. |

| | | |
|---|---------------|-------------|
| DIMENSIONS OF THE MAIN OVEN CAVITY | Height | 320 mm. |
| | Width | 420 mm. |
| | Depth | 390 mm. |
| | Oven capacity | 53.2 litres |

| | | |
|--|---------------|-----------|
| DIMENSIONS OF THE LOWER OVEN CAVITY | Height | 185 mm. |
| | Width | 420 mm. |
| | Depth | 400 mm. |
| | Oven capacity | 31 litres |

Upper oven ratings

| | |
|------------------------|-----------------|
| Oven element | 1.89 kW |
| Top element | 0.834 kW |
| Bottom element | 1.055 kW |
| Convection element | 2.08 kW |
| Grill element | 1.82 kW |
| Double Grill element | 2.655 kW |
| Pizza Oven Function | 3.135 kW |
| Bread Proving Function | 1.89 kW |
| Convection Fan | 30 W |
| Oven Light | 15 W |
| Cooling Fan | 25 W |
| Total Rating | 3.200 kW |

Lower oven ratings

| | |
|-----------------------------|-----------------|
| Oven element | 1.89 kW |
| Top element | 0.834 kW |
| Grill element | 1.82 kW |
| Double Grill element | 2.655 kW |
| Oven Light | 15 W |
| Total Rating | 2.695 kW |
| Total connected load | 5.870 kW |

Electrical Connection

The oven is designed to be connected to 230-240V (50Hz) electricity supply.

The oven has an easily accessible terminal block which is marked as follows:

- Letter L - Live terminal
 Letter N - Neutral terminal
 or E - Earth terminal

THIS OVEN MUST BE EARTHED

The cable used to connect the oven to the electrical supply must comply to the specifications given below.

| Connection via | Min. size Cable/flex | Cable / flex type | Fuse |
|----------------------------|----------------------|------------------------|------|
| For Uk use only | | | |
| • Cooker Control Circuit | 6 mm ² | PVC/PVC twin and earth | 30 A |
| For Europe use only | | | |
| | 4 mm ² | H05 RR-F | 30 A |

It is necessary that you install a double pole switch between the oven and the electricity supply (mains), with a minimum gap of 3mm between the switch contacts and of a type suitable for the required load in compliance with the current rules.

The switch must not break the yellow and green earth cable at any point.

Important

After installation and connecting, the cable must be placed so that it cannot at any point reach a temperature of more than 60°C above the ambient temperature.

Before the oven is connected, check that the main fuse and the domestic installation can support the load; and that the power supply is properly earthed.

The manufacturer disclaims any responsibility should these safety measures not be carried out.

Building In



The oven must be installed according to the instructions supplied. Any electrical work must be undertaken by a qualified electrician/competent person, in accordance with existing rules and regulations.

It is dangerous to alter the specifications or modify the oven in any way.

Please ensure that when the oven is installed it is easily accessible for the engineer in the event of a breakdown.

BUILDING IN

The surround or cabinet into which the oven will be built must comply with these specifications:

- the dimensions must be as shown in the relevant diagrams;
- the materials must withstand a temperature increase of at least 60°C above ambient;
- proper arrangements must be made of a continuous supply of air to the oven to prevent the oven overheating.

Securing The Oven To The Cabinet

1. Fit the oven into the cabinet recess,
2. Open the oven door
3. Secure the oven to the kitchen cabinet with four wood screws, which fit the holes provided in the oven frame.

